

### FEATURES

- 3.5" capacitive touch panel (320x240 pixels)
- Available in the following colors: silver (RAL 9006), anthracite black (RAL 9004), white (RAL 9016) and gloss white (RAL 9003)
- Up to 7 configurable pages and another one for settings
- Built-in temperature, humidity, luminosity and proximity sensors
- Clock functionality (subject to updating through devices with RTC or NTP client)
- 2 independent thermostats
- 4 analog/digital inputs
- Total data saving on KNX bus failure
- Integrated KNX BCU (TP1-256)
- Dimensions 86 x 86 x 34.4 mm
- Flush mount on back box
- Conformity with the CE, UKCA, RCM directives (marks on the back side)

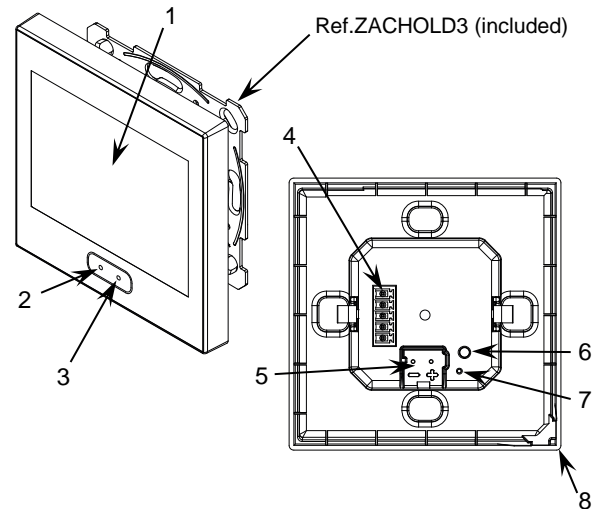

Figure 1: Z35 v2

1. Touch display	2. Illuminated Home button	3. Luminosity and proximity sensor	4. Inputs connector
5. KNX connector	6. Programming button	7. Programming LED indicator	8. Temperature and humidity sensor

Programming button: short press to set programming mode. If this button is held while plugging the device into the KNX bus, it enters the safe mode.

Programming LED: programming mode indicator (red). When the device enters the safe mode, it blinks (red) every half second. During the start-up (reset or after KNX bus failure) and if the device is not in safe mode, it emits a red flash.

### GENERAL SPECIFICATIONS

CONCEPT		DESCRIPTION		
Type of device		Electric operation control device		
KNX supply	Voltage (typical)	29 VDC SELV		
	Voltage range	21-31 VDC		
	Maximum consumption	Voltage	mA	mW
		29 VDC (typical)	19.6	568.4
24 VDC <sup>1</sup>	25	600		
Connection type		Typical TP1 bus connector for 0.8 mm Ø rigid cable		
External power supply		Not required		
Operation temperature		0 .. +55 °C		
Storage temperature		-20 .. +55 °C		
Operation humidity		5 .. 95%		
Storage humidity		5 .. 95%		
Complementary characteristics		Class B		
Protection class		III		
Operation type		Continuous operation		
Device action type		Type 1		
Electrical stress period		Long		
Degree of protection		IP20, clean environment		
Installation		Flush mount on back box		
Minimum clearances		Not required		
Response on KNX bus failure		Data saving according to parameterization		
Response on KNX bus restart		Data recovery according to parameterization		
Operation indicator		The programming LED indicates programming mode (red). Display allows visual feedback of the functionality.		
Weight		118 g		
PCB CTI index		175 V		
Housing material		PC+ABS FR V0 halogen free		

<sup>1</sup> Maximum consumption in the worst-case scenario (KNX Fan-In model).

INPUTS SPECIFICATIONS AND CONNECTIONS	
CONCEPT	DESCRIPTION
Number of inputs	4
Inputs per common	4
Operation voltage	+3.3 VDC in the common
Operation current	1 mA @ 3.3 VDC (per input)
Switching type	Dry voltage contacts between input and common
Connection method	Pluggable screw terminal block (0.3 Nm max.)
Cable cross-section	0.2-1 mm <sup>2</sup> (IEC) / 26-16 AWG (UL)
Maximum cable length	30 m
NTC accuracy (@ 25 °C) <sup>2</sup>	±0.5 °C
Temperature resolution	0.1 °C
Maximum response time	10 ms

<sup>2</sup> For Zennio temperature probes.

TEMPERATURE AND HUMIDITY SENSOR SPECIFICATIONS	
CONCEPT	DESCRIPTION
Temperature measurement range	-40 .. 90 °C
Temperature resolution / accuracy	0.1 °C / ±0.5 °C (@ 25 °C)
Humidity measurement range	0 .. 100% RH
Humidity response time	1 s
Humidity resolution / accuracy	1% / ±5% RH
Humidity drift	±0.25% RH per year in normal air

## INPUTS CONNECTION

Any combination of the following accessories is allowed in the inputs:

### Temperature Probe\*\*

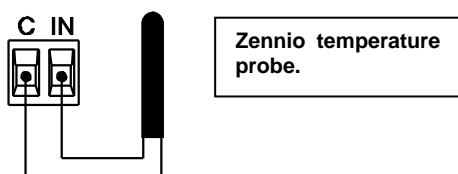

### Motion Sensor

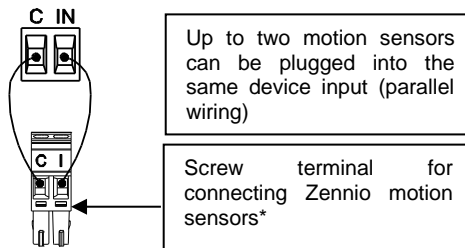

### Switch/Sensor/ Push button

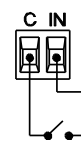

⚠ Commons of different devices must not be connected together.

\* In case of using ZN1IO-DETEC-P sensor, its micro switch number 2 must be in **Type B position**.

\*\* Zennio temperature probe or any NTC with known resistance values at three points in the range [-55, 150 °C].

## INSTALLATION INSTRUCTIONS

1. Fix the metal plate into a square or round back box by using the screws from the box, checking that it is levelled.
2. Connect the KNX bus and the inputs terminal to the back of the device.
3. Fit the device into its final position and check that the strength of the clips is enough to fix the device.

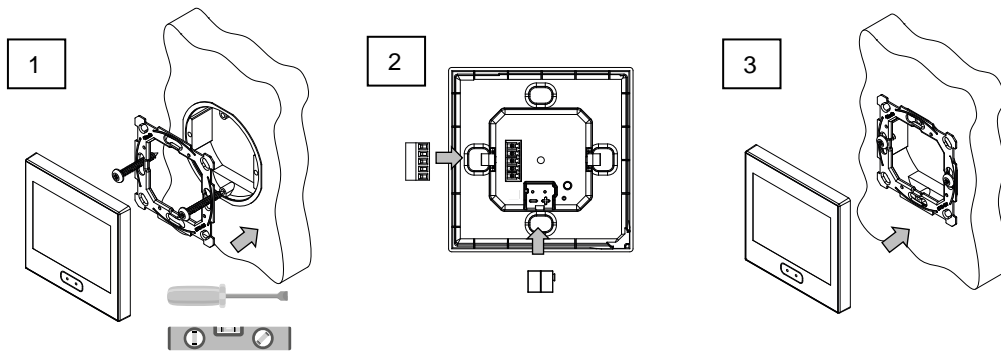

### ⚠ IMPORTANT:

The mounting location must not be exposed to airflows or direct sun radiation.

## DIMENSIONS (mm)

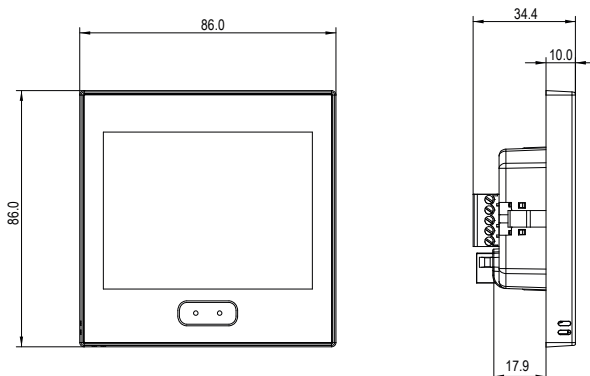

## ⚠ SAFETY INSTRUCTIONS AND ADDITIONAL NOTES

- Installation should only be performed by qualified professionals according to the laws and regulations applicable in each country.
- Do not connect the mains voltage nor any other external voltage to any point of the KNX bus; it would represent a risk for the entire KNX system. The facility must have enough insulation between the mains (or auxiliary) voltage and the KNX bus or the wires of other accessories, in case of being installed.
- Keep the device away from water (condensation over the device included) and do not cover it with clothes, paper or any other material while in use.
- The WEEE logo means that this device contains electronic parts and it must be properly disposed of by following the instructions at <https://www.zennio.com/en/legal/weee-regulation>.
- This device contains software subject to specific licences. For details, please refer to <https://zennio.com/licenses>.